

Expansion Module EM-SYS

Frequency Inverter 230 V / 400 V

**ACTIVE and
ACTIVE Cube**



BONFIGLIOLI

General points on the documentation

The present supplement of the documentation is valid for the frequency inverter series ACT and ACU. The information necessary for the assembly and application of the EM-SYS expansion module is documented in this guidance.

For better clarity, the user documentation is structured according to the customer-specific demands made of the frequency inverter.

Brief instructions

The brief instructions describe the fundamental steps for mechanical and electrical installation of the frequency inverter. The guided commissioning supports you in the selection of necessary parameters and the software configuration of the frequency inverter.

Operating instructions

The operating instructions document the complete functionality of the frequency inverter. The parameters necessary for specific applications for adaptation to the application and the extensive additional functions are described in detail.

Application manual

The application manual supplements the documentation for purposeful installation and commissioning of the frequency inverter. Information on various subjects connected with the use of the frequency inverter is described specific to the application.

Installation instructions

The installation instructions describe the mechanical installation and use of devices which differ from those described in the brief instructions and the operating instructions.

The documentation and additional information can be requested via your local representation of the company BONFIGLIOLI.

The following pictograms and signal words are used in the documentation:



Danger!

means a directly threatening danger. Death, serious damage to persons and considerable damage to property will occur if the precautionary measure is not taken.



Warning!

marks a possible threat. Death, serious damage to persons and considerable damage to property can be the consequence if attention is not paid to the text.



Caution!

refers to an indirect threat. Damage to people or property can be the result.

Attention!

refers to a possible operational behavior or an undesired condition, which can occur in accordance with the reference text.

Note

marks information, which facilitates handling for you and supplements the corresponding part of the documentation.



Warning! In installation and commissioning, comply with the information in the documentation. You as a qualified person must have read the documentation carefully and understood it. Comply with the safety instructions. For the purposes of the instructions, "qualified person" designates a person acquainted with the erection, assembly, commissioning and operation of the frequency inverters and possessing the qualification corresponding to the activity.

TABLE OF CONTENTS

1	General safety and application information	4
1.1	General information.....	4
1.2	Proper use.....	4
1.3	Transport and storage	5
1.4	Handling and positioning.....	5
1.5	Electrical connection.....	5
1.6	Operation information	5
1.7	Maintenance and service	5
2	Introduction	6
3	Installation of the EM-SYS expansion module.....	7
3.1	General	7
3.2	Mechanical installation	7
3.3	Electrical installation	9
3.3.1	Circuit diagram	9
3.3.2	Control terminals	10
4	System bus interface.....	11
4.1	Bus termination	11
4.2	Cables	12
4.3	Socket X410B.....	12
4.4	Baud rate setting/line length	13
4.5	Setting node address	13
4.6	Functional overview	14
4.7	Network management	14
4.7.1	SDO channels (parameter data)	15
4.7.2	PDO channels (process data)	15
4.8	Master functionality.....	16
4.8.1	Control boot-up sequence, network management	16
4.8.2	SYNC telegram, generation.....	18
4.8.3	Emergency message, reaction.....	19
4.8.4	Client SDO (system bus master).....	20
4.9	Slave functionality	21
4.9.1	Implement boot-up sequence, network management.....	21
4.9.1.1	Boot-up message	21
4.9.1.2	Status control	21
4.9.2	Process SYNC telegram	22
4.9.3	Emergency message, fault switch-off.....	23
4.9.4	Server SDO1/SDO2	24

TABLE OF CONTENTS

4.10	Communication channels, SDO1/SDO2	26
4.10.1	SDO telegrams (SDO1/SDO2)	26
4.10.2	Communication via field bus connection (SDO1)	28
4.10.2.1	Profibus-DP	28
4.10.2.2	RS232/RS485 with VECTRON bus protocol	28
4.11	Process data channels, PDO	30
4.11.1	Identifier assignment process data channel.....	30
4.11.2	Operation modes process data channel.....	31
4.11.3	Timeout monitoring process data channel	32
4.11.4	Communication relationships of the process data channel	33
4.11.5	Virtual links	34
4.11.5.1	Input parameters of the TxPDO's for data to be transmitted	37
4.11.5.2	Source numbers of the RxPDO's for received data.....	39
4.11.5.3	Examples of virtual links	40
4.12	Control parameters	41
4.13	Handling of the parameters of the system bus	42
4.14	Utilities	44
4.14.1	Definition of the communication relationships.....	45
4.14.2	Production of the virtual links.....	46
4.14.3	Capacity planning of the system bus.....	47
5	Parameter list	49
5.1	Actual value menu (VAL)	49
5.2	Parameter menu (PARA)	49
6	Annex	51
6.1	Error messages	51

1 General safety and application information

This documentation has been created with greatest care and has been extensively and repeatedly checked. For reasons of clarity, we have not been able to take all detailed information on all the types of the products and also not every imaginable case of positioning, operation or maintenance into account. If you require further information or if particular problems not treated extensively enough in the operating instructions occur, you can obtain the necessary information via the local representation of the company BONFIGLIOLI.

In addition, we would point out that the contents of these operating instructions are not part of an earlier or existing agreement, assurance or legal relationship, nor are they intended to amend them. All the manufacturer's obligations result from the purchase contract in question, which also contains the completely and solely valid warranty regulation. These contractual warranty provisions are neither extended nor limited by the implementation of these operating instructions.

The manufacturer reserves the right to correct or amend the contents and product information as well as omissions without specific announcement and assumes no kind of liability for damage, injuries or expenditure to be put down to the aforementioned reasons.

1.1 General information



Warning! BONFIGLIOLI VECTRON frequency inverters have high voltage levels during operating, depending on their protection class, drive moving parts and have hot surfaces.

In the event of inadmissible removal of the necessary covers, improper use, wrong installation or operation, there is the risk of serious damage to persons or property.

To avoid the damage, only qualified staff may carry out the transport, installation, setup or maintenance work required. Comply with the standards EN 50178, IEC 60364 (Cenelec HD 384 or DIN VDE 0100), IEC 60664-1 (Cenelec HD 625 or VDE 0110-1), BGV A2 (VBG 4) and national provisions. Qualified persons within the meaning of this principal safety information are people acquainted with the erection, fitting, commissioning and operating of frequency inverters and the possible hazards and in possession of qualifications matching their activities.

1.2 Proper use



Warning! The frequency inverters are electrical drive components intended for installation in industrial plant or machines. Commissioning and start of intended operation are not allowed until it has been established that the machine corresponds to the provisions of the EC machine directive 98/37/EEC and EN 60204. According to the CE sign, the frequency inverters additionally fulfill the requirements of the low-voltage directive 73/23/EEC and the standards EN 50178 / DIN VDE 0160 and EN 61800-2. Responsibility for compliance with the EMC directive 89/336/EEC is with the user. Frequency inverters are available in a limited way and as components exclusively intended for professional use within the meaning of the standard EN 61000-3-2.

With the issue of the UL certificate according to UL508c, the requirements of the CSA Standard C22.2-No. 14-95 have also been fulfilled.

The technical data and the information on connection and ambient conditions stated on the rating plate and the documentation must be complied with. The instructions must have been read and understood before starting work at the device.

1.3 Transport and storage

Transport and storage are to be done appropriate in the original packing. Store the units only in dry rooms, which are protected against dust and moisture and are subjected to little temperature deviations only. Observe the climatic conditions according to standard EN 50178 and to the information on the label of the original packing. The duration of storage without connection to the admissible reference voltage may not exceed one year.

1.4 Handling and positioning



Warning! Damaged or destroyed components may not be put into operation because they may be a health hazard.

The frequency inverters are to be used according to the documentation, the directives and the standards. Handle carefully and avoid mechanical overload. Do not bend the components or change the isolation distances. Do not touch electronic components or contacts. The devices contain construction elements with a risk of electrostatic, which can easily be damaged by improper handling. Any use of damaged or destroyed components shall be considered as a non-compliance with the applicable standards. Do not remove any warning signs from the device.

1.5 Electrical connection



Warning! Before any assembly or connection work, de-energize the frequency inverter.

Do not touch the sockets, because the capacitors may still be charged.

Make sure that the frequency inverter is de-energized.

Comply with the information given in the operating instructions and on the frequency inverter label.

While working on the frequency inverters, obey the applicable standards BGV A2 (VGB 4), VDE 0100 and other national directives. Comply with the information in the documentation on electrical installation and the relevant directives.

Responsibility for compliance with and examination of the limit values of the EMC product standard EN 61800-3 for variable-speed electrical drive mechanisms is with the manufacturer of the industrial plant or machine.

The documentation contains information on installation correct for EMC. The cables connected to the frequency inverters may not be subjected to an isolation test with a high test voltage without previous circuit measures.

1.6 Operation information



Warning! In the case of a short supply voltage failure, the motor may restart spontaneously.

If staff is endangered, a restart of the motor must be prevented by means of external circuitry.

Before commissioning and the start of the intended operation, attach all the covers and check the sockets. Check additional monitoring and protective devices pursuant to EN 60204 and the safety directives applicable in each case (e.g. Working Machines Act, Accident Prevention Directives etc.).

No connection work may be performed, while the system is in operation.

1.7 Maintenance and service



Warning! Unauthorized opening and improper interventions can lead to physical injury or damage to property. Repairs on the frequency inverters may only be done by the manufacturer or persons authorized by the latter.

2 Introduction

This document describes the possibilities and the properties of the EM-SYS expansion module for the frequency inverters of the ACT and ACU series of devices.

Note: This document exclusively describes the EM-SYS expansion module. It does not provide basic information on the operation of the ACT and ACU series frequency inverters.

The EM-SYS expansion module is an optional hardware component to extend the functionality of the frequency inverter. It enables the data exchange within the network and between the components, which have been directly connected, for example control and regulation elements.

The EM-SYS expansion module is supported from device series ACU and as from software version 4.1.0 of device series ACT.

The EM-SYS module extends the functionality of the frequency inverters of the ACT and ACU series of devices by the following additional functions:

- **CAN system bus**
(CAN interface ISO-DIS 11898, CAN High Speed, max. 1 MBaud)

Note: The EM-SYS expansion module has been enclosed with the frequency inverter as a separate component and must be fitted by the user. This is described in detail in the chapter "Mechanical Installation".

To assemble the expansion module it can be simply plugged into the frequency inverters of the ACT and ACU device series.



Warning! Carry out the assembly before the frequency inverter is put into operation, and only in a voltage-free state.

The pluggable sockets of the expansion module enable economical overall fitting with a safe function.

3 Installation of the EM-SYS expansion module

3.1 General

The mechanical and electrical installation of the EM-SYS expansion module is to be carried out by qualified personnel according to the general and regional safety and installation directives. Safe operation of the frequency inverter requires that the documentation and the device specification be complied with during installation and start of operation. For specific areas of application further provisions and guidelines must be complied with where applicable.

The frequency inverters are designed according to the requirements and limit values of product standard EN 61800-3 with an interference immunity factor (EMI) for operation in industrial applications. The electromagnetic interference is to be avoided by expert installation and observation of the specific product information.

For further information, refer to the chapter "Electrical Installation" of the frequency inverter operating instructions.



Warning! All connection terminals where dangerous voltage levels may be present (e.g. motor connection terminals, mains terminals, fuse connection terminals, etc.) must be protected against direct contact.

3.2 Mechanical installation



Danger! If the following instructions are not complied with, there is direct danger with the possible consequences of death or severe injury by electrical current. Further, failure to comply can lead to destruction of the frequency inverter and/or of the expansion module.

- Before assembly or disassembly of the EM-SYS expansion module, the frequency inverter must be de-energized. Take appropriate measures to make sure it is not energized unintentionally.
- Make sure that the frequency inverter is de-energized.



Danger! The mains, direct voltage and motor sockets can have dangerous voltages even after disconnection of the frequency inverter. Work may only be done on the device after a waiting period of some minutes until the DC link capacitors have been discharged.

The EM-SYS expansion module is supplied in a housing for assembly on the lower slot of the frequency inverter.

- Remove the lower cover (1) of the frequency inverter. The slot for the EM-SYS expansion module becomes accessible

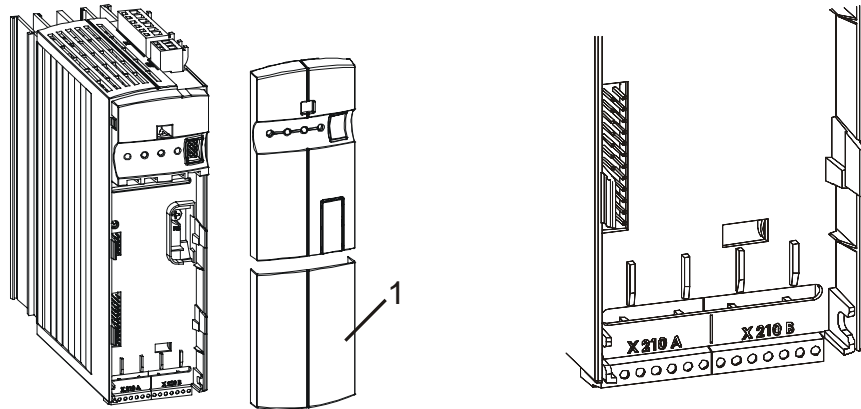

Caution! The EM-SYS expansion module (2) is pre-fitted in a housing. Do NOT touch the PCB visible on the back, as modules may be damaged.

- Plug the EM-SYS expansion module (2) onto the slot (3).

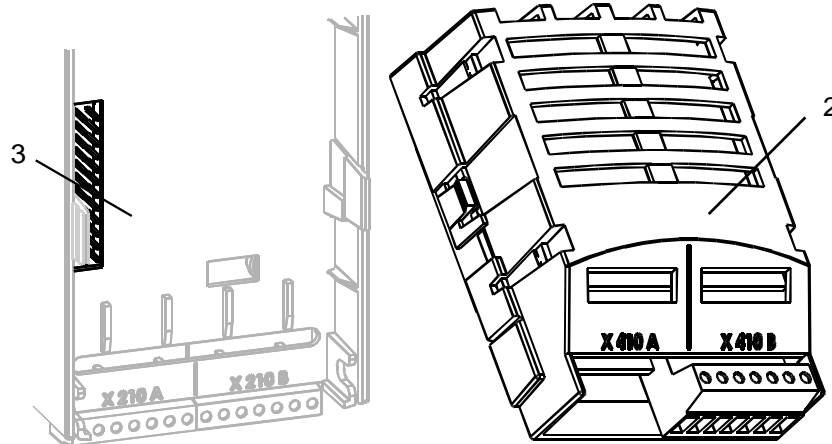

- Re-install the lower cover (1). This completes the assembly procedure.

When the supply voltage of the frequency inverter is switched on, the EM-SYS expansion module is ready for operation.

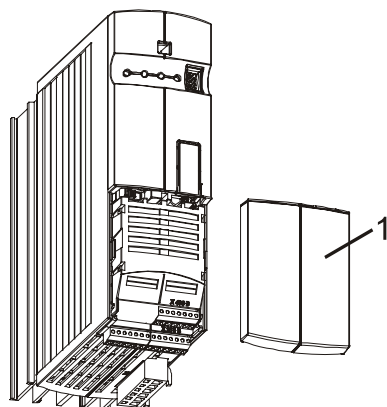

3.3 Electrical installation



Danger! If the following instructions are not complied with, there is direct danger with the possible consequences of death or severe injury by electrical current. Further, failure to comply can lead to destruction of the frequency inverter and/or of the expansion module.

- Before assembly or disassembly of the EM-SYS expansion module, the frequency inverter must be de-energized. Take appropriate measures to make sure it is not energized unintentionally.
- Make sure that the frequency inverter is de-energized.



Danger! The mains, direct voltage and motor sockets can have dangerous voltages even after disconnection of the frequency inverter. Work may only be done on the device after a waiting period of some minutes until the DC link capacitors have been discharged.

3.3.1 Circuit diagram

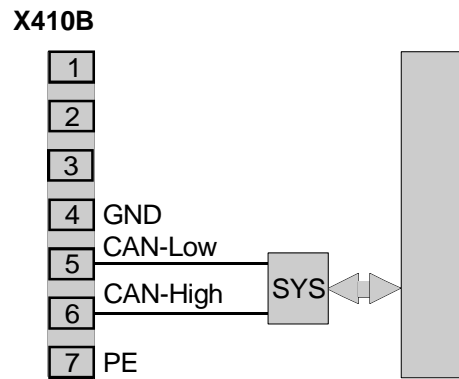

Communication interface system bus

CAN actuation of the system bus according to ISO-DIS 11898 (CAN High Speed)

The terminals without designations are not assigned any functions.

3.3.2 Control terminals

The control and software functionality can be freely configured for economical operation with a safe function.

Expansion module EM-SYS

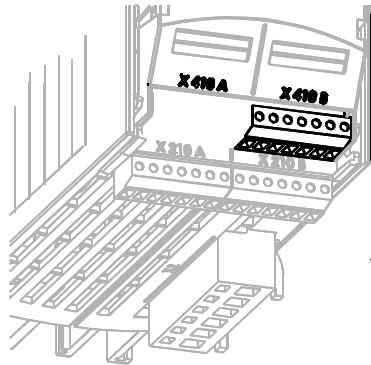

Wieland DST85 / RM3,5

 0.14 ... 1.5 mm²
AWG 30 ... 16

 0.14 ... 1.5 mm²
AWG 30 ... 16

 0.25 ... 1.0 mm²
AWG 22 ... 18

 0.25 ... 0.75 mm²
AWG 22 ... 20

0.2 ... 0.3 Nm
1.8 ... 2.7 lb-in



Caution! The control inputs and outputs must be connected and separated free of power. Otherwise, components may be damaged.

- The unit may only be connected with the power supply switched off.
- Make sure that the frequency inverter is de-energized.

Socket X410B

Ter.	Description
1	no function
2	no function
3	no function
4	Earth / GND
5	System bus, CAN low
6	System bus, CAN high
7	PE

4 System bus interface

The CAN connection of the system bus is physically designed according to **ISO-DIS 11898** (CAN High Speed). The bus topology is the line structure.

In the default version, the frequency inverter supports a CAN protocol controller, which may exist in **either** the CM-CAN communication module with CANopen interface **OR** in an expansion module for the system bus, such as the EM-SYS expansion module.

Attention! Installation of two optional components with CAN-Protocol controller results in a deactivation of the system bus interface in the EM-SYS expansion module.

4.1 Bus termination

The necessary bus terminator at the physically first and last node can alternatively be activated via the two DIP switches **S1** and **S2** on the EM-SYS expansion module.

- Either set **S1** to ON and **S2** to OFF for a regular **passive** termination,
- or set **S1 and S2** to ON for an **active** termination. This results in an improved edge shape of the CAN signals, which improves the signal shapes, in particular in extended systems.

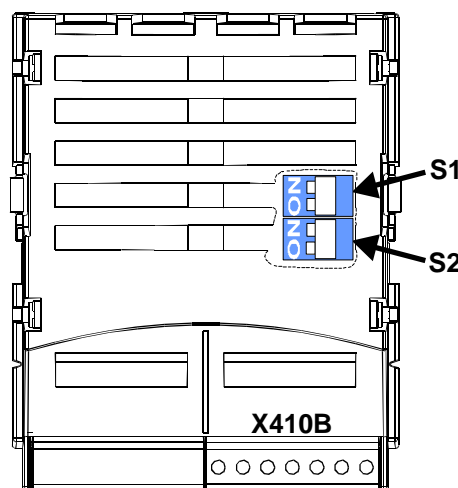

Attention! The factory setting for the bus termination is **OFF**.

The active termination via the DIP switches **S1** and **S2** may only be activated in **one** expansion module. The other bus termination must be passive.

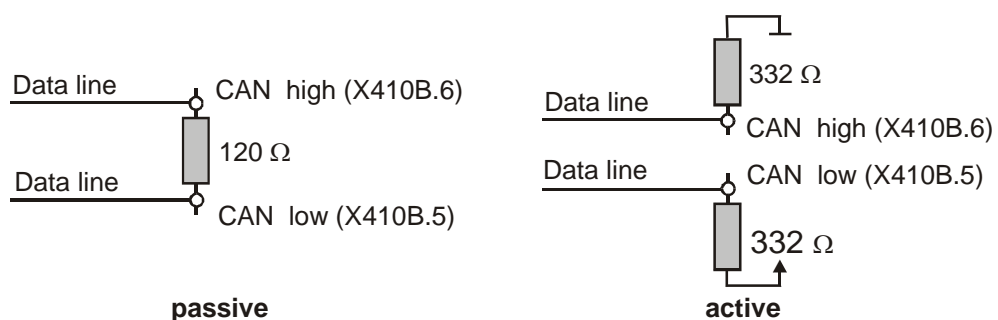

4.2 Cables

For the bus line, use twisted cable with harness shield (**no foil shield**).

Attention! The control and communication lines are to be laid physically separate from the power lines. The harness screen of the data lines is to be connected to ground (PE) on both sides on a large area and with good conductivity.

4.3 Socket X410B

The system bus is connected via the terminals **4**, **5** and **6** of the socket **X410B** on the EM-SYS expansion module.

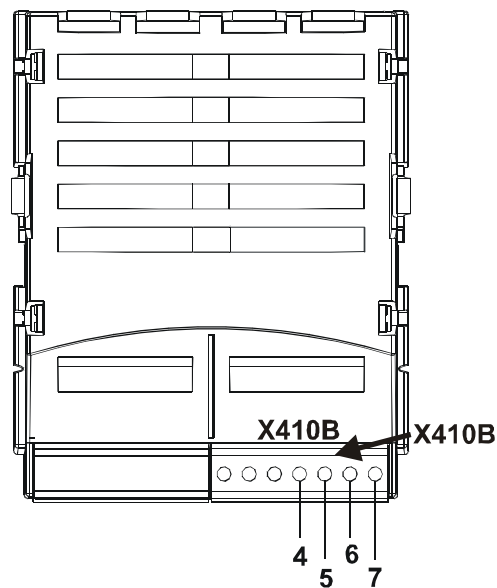

Socket X410B

Terminal	Input/Output	Description
(4): X410B.4	GND	CAN-GND (System bus)
(5): X410B.5	CAN-Low	CAN-Low (System bus)
(6): X410B.6	CAN-High	CAN-High (System bus)
(7): X410B.7	PE	PE

4.4 Baud rate setting/line length

The setting of the baud rate must be identical in all nodes on the system bus. The maximum possible baud rate is based on the necessary overall line length of the system bus. The baud rate is set via the parameter *Baud-Rate* **903** and thus defines the possible line length.

Operation mode	Function	max. line length
3 - 50 kBaud	Transmission rate 50 kBaud	1000 meters
4 - 100 kBaud	Transmission rate 100 kBaud	800 meters
5 - 125 kBaud	Transmission rate 125 kBaud	500 meters
6 - 250 kBaud	Transmission rate 250 kBaud	250 meters
7 - 500 kBaud	Transmission rate 500 kBaud	100 meters
8 - 1000 kBaud	Transmission rate 1000 kBaud	25 meters

A baud rate under 50 kBaud, as is defined according to CANopen, is not sensible for the system bus as the data throughput is too low.

The maximum line lengths stated are guidelines. If they are made complete use of, a calculation of the admissible length is to be done on the basis of the line parameters and the bus driver (PCA82C250T).

4.5 Setting node address

A maximum of 63 slaves or frequency inverters with system bus can be operated on the system bus. Each frequency inverter is given a node ID, which may only exist once in the system, for its unambiguous identification. The setting of the system bus node ID is done via the parameter *Node-ID* **900**.

Parameter		Setting		
No.	Description	min.	max.	Factory setting
900	Node-ID	-1	63	-1

Thus, the system bus possesses a maximum number of 63 nodes (Network nodes), plus one frequency inverter as a master.

Note: With the factory setting of parameter *Node-ID* **900** = -1, the system bus is deactivated for this frequency inverter.
 If the *Node-ID* **900** = 0 is set, the frequency inverter is defined as a master. Only one frequency inverter on the system bus may be defined as a master.

4.6 Functional overview

To start with, the system bus produces the physical connection between the frequency inverters. Logical communication channels are produced via this physical medium. These channels are defined via the identifiers. As CAN does not possess a node-oriented, but a message-oriented addressing via the identifiers, the logical channels can be displayed via it.

In the basic state (factory setting) the identifiers are set according to the Predefined Connection Set of CANopen. These settings are aimed at one master serving all the channels. In order to be able to build up process data movement via the PDO channels between individual or a number of inverters (transverse movement), the setting of the identifiers in the nodes has to be adapted.

Note: For understanding, it is important to observe that the data exchange is done message-oriented. The frequency inverter can transmit and receive a number of messages, identified via various identifiers.

As a special feature, the properties of the CAN bus mean that the messages transmitted by one node can be received by a number of nodes simultaneously. The error monitoring methods of the CAN bus result in the message being rejected by all recipients and automatically transmitted again if there is a faulty reception in one receiver.

4.7 Network management

The network management controls the start of all the nodes on the system bus. Nodes can be started or stopped individually or together. For node recognition in a CAN or CANopen system, the slaves on the system bus generate a starting telegram (boot-up report).

If a fault occurs, the slaves automatically transmit a fault report (emergency message).

For the functions of the network management, the methods and NMT telegrams (network management telegrams) defined according to CANopen (CiA DS 301) are used.

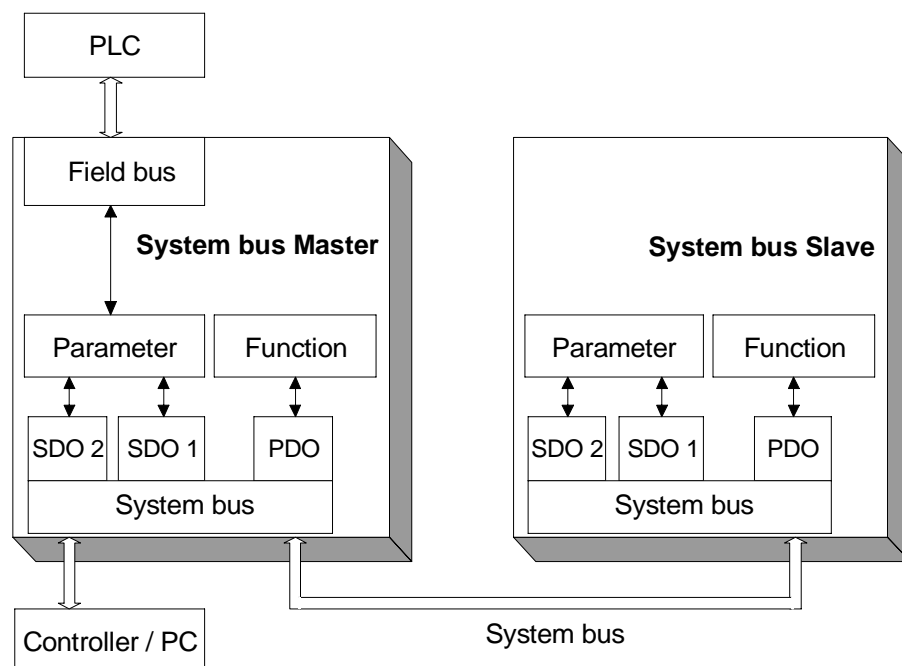

4.7.1 SDO channels (parameter data)

Each frequency inverter possesses two SDO channels for the exchange of parameter data. In a slave device, these are two server SDO's, in a device defined as a master a client SDO and a server SDO. Attention must be paid to the fact that only one master for each SDO channel may exist in a system.

Note: Only one master can initiate by the system bus an exchange of data via its client SDO.

The identifier assignment for the SDO channels (Rx/Tx) is done according to the Pre-defined Connection Set.

This assignment can be amended by parameterization, in order to solve identifier conflicts in a larger system in which further devices are on the CAN bus alongside the frequency inverters.

Attention! In a system in which a frequency inverter works as a master, the identifier allocations for the SDO channel may not be altered.
In this way, an addressing of individual nodes via the field bus/system bus path of the master frequency inverter is possible.

Parameters are read/written via the SDO channels. With the limitation to the SDO Segment Protocol Expedited, which minimizes the handling needed for the parameter exchange, the transmittable data are limited to the uint / int / long types. This permits complete parameterization of the frequency inverters via the system bus, as all the settings and practically all the actual values are displayed via these data types.

4.7.2 PDO channels (process data)

Each frequency inverter possesses three PDO channels (Rx/Tx) for the exchange of process data.

The identifier assignment for the PDO channel (Rx/Tx) is done by default according to the Predefined Connection Set. This assignment corresponds to an alignment to a central master control.

In order to produce the logical channels between the devices (transverse movement) on the system bus, the amendment of the PDO identifiers for Rx/Tx is necessary.

Each PDO channel can be operated with time or SYNC control. In this way, the operation behavior can be set for each PDO channel:

The setting of the operation mode is done via the following parameters:
TxPDO1 Function 930, TxPDO2 Function 932 und TxPDO3 Function 934
RxPDO1 Function 936, RxPDO2 Function 937 und RxPDO3 Function 938

Operation mode	Function
0 - deactivated	no exchange of data via the PDO channel (Rx and/or Tx)
1 - time-controlled	Tx-PDO's cyclically transmit according to the time specification Rx-PDO's are read in with $T_a = 1$ ms and forward the data received to the application
2 - SYNC controlled	Tx-PDO's transmit the data from the application that are then current after the arrival of the SYNC telegram. Rx-PDO's forward the last data received to the application after the arrival of the SYNC telegram.

For synchronous PDO's, the master (PC, PLC or frequency inverter) generates the SYNC telegram. The identifier assignment for the SYNC telegram is done by default according to the Predefined Connection Set. This assignment can be altered by parameterization.

4.8 Master functionality

An external control or a frequency inverter defined as a master (node ID = 0) can be used as a master. The fundamental tasks of the master are controlling the start of the network (boot-up sequence), generating the SYNC telegram and evaluating the emergency messages of the slaves.

Further, there can be access to the parameterization of all the frequency inverters on the system bus by means of a field bus connection via the client SDO of the master frequency inverter.

4.8.1 Control boot-up sequence, network management

The Minimum Capability Boot-Up method defined according to CANopen is used for the state control of the nodes (nodes).

This method knows the pre-operational, operational and stopped states.

After the initialization phase, all the nodes are in the pre-operational state. The system bus master transmits the NMT command **Start-Remote-Node**. With this command, individual nodes or all the nodes can be started together. The frequency inverter defined as a master starts **all** the nodes with **one** command. After receipt of the Start Remote Node command, the nodes change into the Operational state. From this time on, process data exchange via the PDO channels is activated.

A master in the form of a PLC/PC can start the nodes on the system bus individually and also stop them again.

As the slaves on the system bus need different lengths of time to conclude their initialization phases (especially if external components exist alongside the frequency inverters), an adjustable delay for the change to Operational is necessary.

The setting is done in a frequency inverter defined as a system bus master via *Boot-Up Delay 904*.

Parameter		Setting		
No.	Description	Min.	Max.	Factory setting
904	Boot-Up Delay	3500 ms	50000 ms	3500 ms

Properties of the states:

State	Properties
Pre-Operational	Parameterization via SDO channel possible Exchange of process data via PDO channel not possible
Operational	Parameterization via SDO channel possible Exchange of process data via PDO channel possible
Stopped	Parameterization via SDO channel not possible Exchange of process data via PDO channel not possible

Note: Start-Remote-Node is cyclically transmitted with the set delay time by an frequency inverter defined as a system bus master, in order to put slaves added with a delay or temporarily separated from the network back into the Operational state.

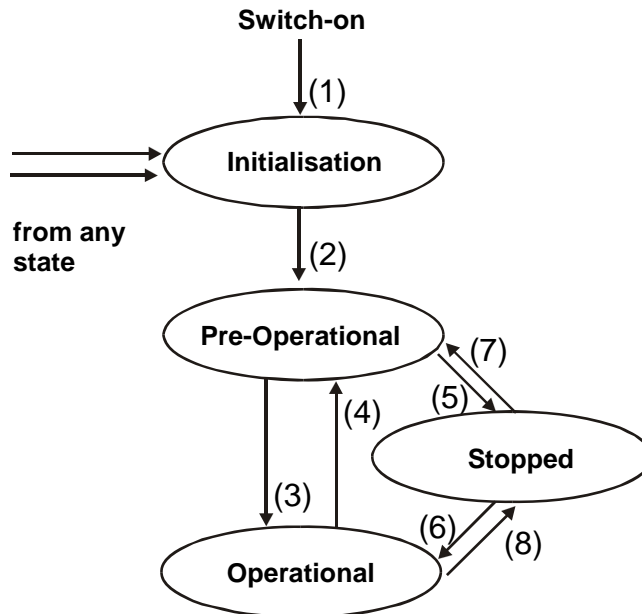

After Power On and the initialization, the slaves are in the Pre-Operational state. The transition (2) is automatic. The system bus master (frequency inverter or PLC/PC) triggers the transition (3) to Operational state. The transitions are controlled via NMT telegrams.

The identifier used for the NMT telegrams is "0" and may only be used by the system bus master for NMT telegrams. The telegram contains two data bytes.

Byte 0	Byte 1
CS (Command Specifier)	Node-ID

Identifier = 0

With the statement of the node ID $\neq 0$, the NMT command acts on the node selected via the node ID. If node ID = 0, **all** the nodes are addressed.

Transition	Command	Command Specifier
(3) , (6)	Start Remote Node	1
(4) , (7)	Enter Pre-Operational	128
(5) , (8)	Stop Remote Node	2
-	Reset Node	129
-	Reset Communication	130

Note: A frequency inverter defined as a system bus master only transmits the command "Start Remote Node" with node ID = 0 (for all nodes). Transmission of the command is done after completion of the initialization phase and the time delay *Boot-Up Delay* **904** following it.

4.8.2 SYNC telegram, generation

If synchronous PDO's have been created on the system bus, the master must send the SYNC telegram cyclically. If a frequency inverter has been defined as a system bus master, the latter must generate the SYNC telegram. The interval for the SYNC telegram of a frequency inverter defined as the system bus master is adjustable. The SYNC telegram is a telegram without data.

The default identifier = 128 according to the Predefined Connection Set.

If a PC or PLC is used as a master, the identifier of the SYNC telegrams can be adapted by parameterization on the frequency inverter. The identifier of the SYNC telegram must be set identically in all nodes on the system bus.

The setting of the identifier of the SYNC telegram is done via the parameter *SYNC-Identifier* **918**.

Parameter		Setting		
No.	Description	Min.	Max.	Fact. sett.
918	SYNC-Identifier	0	2047	0

The setting "0" results in identifier assignment according to the Predefined Connection Set.

Attention! The identifier range 129...191 may not be used as the emergency telegrams can be found there.

The temporal cycle for the SYNC is set on a frequency inverter defined as a system bus master via the parameter *SYNC-Time* **919**.

Note: A setting of 0 ms for the parameter *SYNC-Time* **919** means "no SYNC telegram".

4.8.3 Emergency message, reaction

If a slave on the system bus suffers a fault, it transmits the emergency telegram. The emergency telegram marks the node ID for the identification of the failed node via its identifier and the existing fault message via its data contents (8 bytes).

After a fault has been acknowledged on the slave, the latter again transmits an emergency telegram with the data content zero.

The emergency telegram has the identifier 128 + node ID (= 129 ... 191)

The system bus master evaluates the emergency telegrams of the slaves. Its reaction to an emergency telegram can be set with *Emergency Reaction 989*.

Operation mode	Function
0 - Error	The system bus master receives the emergency telegram and switches-off
1 - No Error	The Emergency Telegram is displayed as warning.

Operation mode - parameter 989 = 0 – Error

Behavior of the system bus master in *Emergency Reaction 989* = 0 / Error:

As soon as the system bus master receives an emergency telegram, it also breaks down and reports the failed node on the basis of its ID via the kind of error. Only the node is reported, not the cause of the error.

The fault message on the system bus master via *Current error 260* is **21nn** with **nn** = **node ID** (hexadecimal) of the slave in which a fault switch-off exists.

In addition, the system bus master reports the warning Sysbus (0x2000) via the parameter *Warnings 270* Bit 13.

If a fault switch-off occurs on a number of slaves, the first slave to transmit its emergency telegram is displayed on the system bus master.

Operation mode - parameter 989 = 1 – No Error

Behavior of the system bus master in *Emergency Reaction 989* = 1 / No Error:

As soon as the system bus master receives an emergency telegram, it reports the warning Sysbus (0x2000) via the parameter *Warnings 270* Bit 13.

Note: In both cases, the Boolean variable SysbusEmergency with source number 730 is set to TRUE in the system bus master. It can be used in the system bus master and (in transmission via a TxPDO) in the slaves for a defined shutdown.

SysbusEmergency is also set if the system bus master breaks down.

Resetting of SysbusEmergency is done with the fault acknowledgment.

4.8.4 Client SDO (system bus master)

Each node on the system bus can be addressed via the SDO channels. In this way, each node can be addressed and parameterized by one master via its client SDO1. All the parameters of the data types uint/int/long are accessible. String parameters cannot be processed. If a frequency inverter has been defined as a system bus master, each node on the system bus in this frequency inverter can be addressed by means of a field bus connection (RS232, RS485, Profibus-DP) via its client SDO1.

Attention! The second SDO channel SDO2 of the frequency inverters is planned for the parameterization of the frequency inverters via a visualization tool on the system bus.

The service used is SDO Segment Protocol Expedited according to CANopen. The frequency inverter defined as a system bus master automatically generates the correct telegrams. If the SDO channel is operated via a PLC/PC on the system bus, the telegrams must be generated according to the specification.

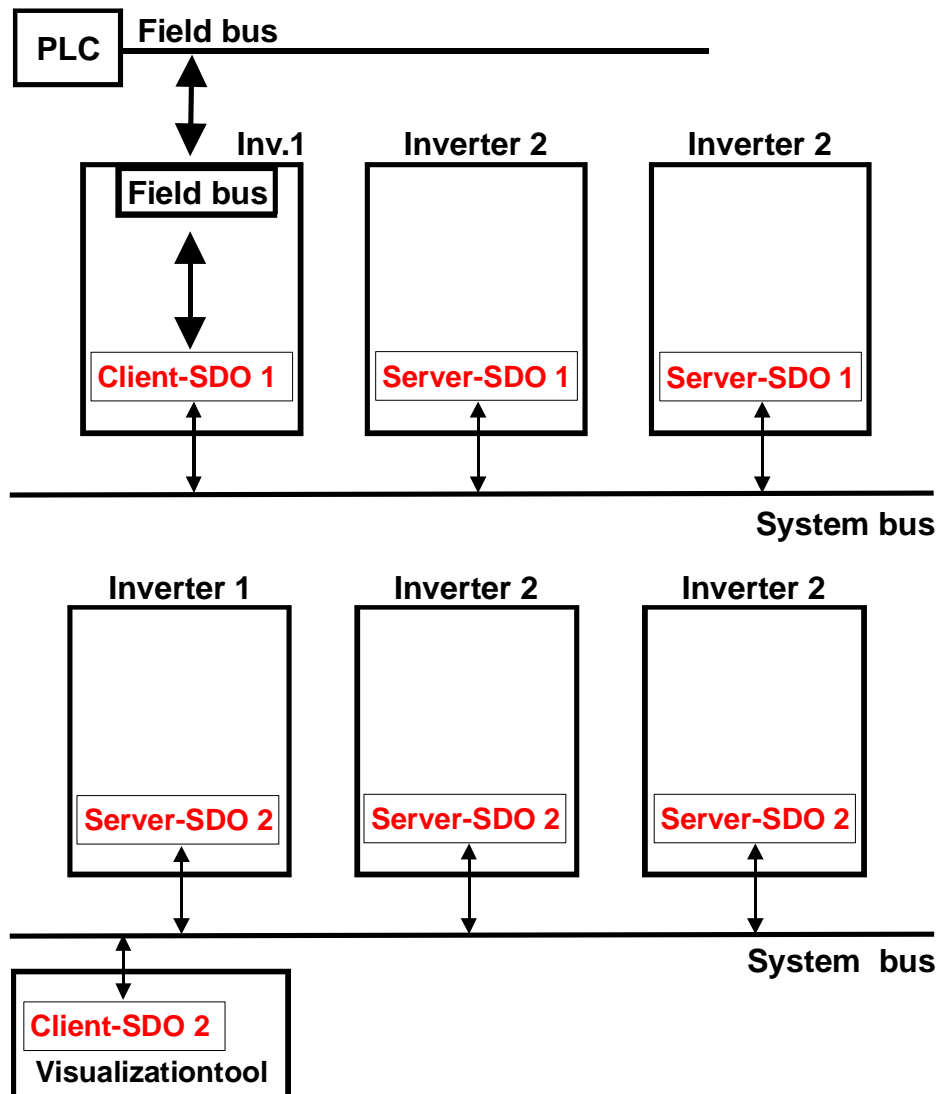

4.9 Slave functionality

4.9.1 Implement boot-up sequence, network management

4.9.1.1 Boot-up message

After the initialization, each slave on the system bus transmits its boot-up message (heartbeat message).

Note: The boot-up telegram has the identifier 1792 + node ID and a data byte with contents = 0x00.

This telegram is of importance if a PLC/PC with CANopen functionality is used as a master. The frequency inverter defined as a system bus master does **not** evaluate the boot-up message.

4.9.1.2 Status control

The identifier used for the NMT telegrams is "0" and may only be used by the system bus master for NMT telegrams. The telegram contains two data bytes.

Byte 0	Byte 1
CS (Command Specifier)	Node-ID

Identifier = 0

With the statement of the node ID \neq 0, the NMT command acts on the node selected via the node ID. If node ID = 0, **all** the nodes are addressed.

Transition	Command	Command Specifier
(3),(6)	Start Remote Node	1
(4),(7)	Enter Pre-Operational	128
(5),(8)	Stop Remote Node	2
-	Reset Node	129
-	Reset Communication	130

Attention! The reset node and reset communication command specified according to DS 301 lead to a change to Pre-Operational via Initialization in the frequency inverters. There is a new boot-up message.

After a slave has received the command "Start Remote Node", it activates the PDO channels and is ready for the exchange of process data.

4.9.2 Process SYNC telegram

If synchronous PDO's have been created in a frequency inverter, their processing is synchronized with the SYNC telegram. The SYNC telegram is generated by the system bus master and is a telegram without data.

The identifier is 128 according to the Predefined Connection Set.

If a PC or PLC is used as a master, the identifier of the SYNC telegrams can be adapted by parameterization on the frequency inverter. The identifier of the SYNC telegram must be set identically in all nodes on the system bus.

Attention! The identifier range 129 ... 191 may not be used as the emergency telegrams can be found there.

The setting of the identifier of the SYNC telegram is done via the parameter *SYNC-Identifier* **918**.

Parameter			Setting	
No.	Description	Min.	Max.	Factory setting
918	SYNC-Identifier	0	2047	0

The setting "0" results in identifier assignment according to the Predefined Connection Set.

The data of the Rx-PDO's are forwarded to the application after the arrival of the SYNC telegram. At the same time, the transmission of the Tx-PDO's with the currently available data from the application is triggered.

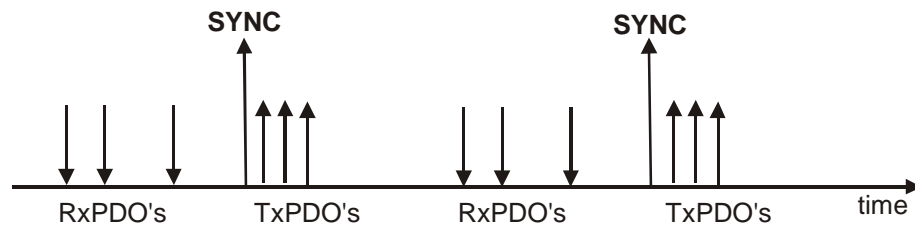

This method enables pre-occupancy of set points in the system bus nodes and a synchronous / parallel take-over of the data.

4.9.3 Emergency message, fault switch-off

As soon as a fault switch-off occurs in a slave frequency inverter, the emergency telegram is transmitted. The emergency telegram marks the node ID for the identification of the failed node via its identifier and the existing fault message via its data contents (8 bytes).

The emergency telegram has the identifier 128 + node ID.

After a fault acknowledgment, another emergency telegram is transmitted, with the data content (Byte 0 ...7) being set to zero this time. This identifies the node's repeated readiness for operation. If a further fault occurs subsequently, it is transmitted in a new emergency telegram.

The acknowledgment sequence is based on the definitions according to CANopen.

Data contents of the emergency telegram:

Emergency telegram		
Byte	Value	Meaning
0	0x00	low-byte Error-Code
1	0x10	high-byte Error-Code
2	0x80	Error-Register
3	0	-
4	0	-
5	0	-
6	0xnn	internal Error-Code, low-byte
7	0xmm	internal Error-Code, high-byte

Bytes 0, 1 and 2 are firmly defined and compatible with CANopen.

Bytes 6/7 contain the product specific VECTRON error code.

Error-Code = 0x1000 = general error
 Error-Register = 0x80 = manufacturer-specific error

The explanation and description of the product-specific VECTRON error code can be found in the annex "Error messages".

4.9.4 Server SDO1/SDO2

The communication channel for the exchange of parameter data is the SDO channel. Communication works according to the client/server model. The server is the node holding the data (here the frequency inverter), the client the node requesting or wanting to alter the data (PLC, PC or frequency inverter as system bus master).

For the frequency inverter, two server SDO channels have been implemented. The first SDO channel **SDO1** is used for the parameterization of the PLC/PC as a master or frequency inverter with field bus connection as a system bus master. The second SDO channel **SDO2** is reserved for a visualization tool for parameterization. An exchange of data can only be implemented by the master via a client SDO.

The SDO channels are stipulated for the server SDO's via identifiers according to the Predefined Connection Set to CANopen. As CANopen only provides for and defines one SDO channel in the Predefined Connection Set, the second SDO channel can be deactivated.

In addition, the number of system bus nodes and the adjustable node ID are limited to 63.

Identifier assignment according to the Predefined Connection Set:

Identifier Rx-SDO = 1536 + Node-ID (Node-ID = 1 ... 127, Identifier = 1537 ... 1663)

Identifier Tx-SDO = 1408 + Node-ID (Node-ID = 1 ... 127, Identifier = 1409 ... 1535)

Identifier assignment for SDO1/SDO2 compatible with the Predefined Connection Set:

Identifier Rx-SDO1 = 1536 + Node-ID (Node-ID = 1 ... 63, Identifier = 1537 ... 1599)

Identifier Tx-SDO1 = 1408 + Node-ID (Node-ID = 1 ... 63, Identifier = 1409 ... 1471)

Identifier Rx-SDO2 = 1600 + Node-ID (Node-ID = 0 ... 63, Identifier = 1600 ... 1663)

Identifier Tx-SDO2 = 1472 + Node-ID (Node-ID = 0 ... 63, Identifier = 1472 ... 1535)

This corresponds to the factory settings of the frequency inverters for the SDO's. The node ID = 0 for SDO2 is the system bus master.

Attention! The SDO2 must be deactivated in a CANopen system in order not to generate any compatibility problems.

If a frequency inverter has been defined as the system bus master, the above settings for the SDO1 must be maintained in all the frequency inverters. In this way, access to the parameterization of the frequency inverters via a field bus connection on the master frequency inverter is possible.

The client SDO1 in the master frequency inverter addresses the server SDO1 of the slaves via the above identifiers.

Attention! The identifiers for a visualization tool on the second SDO channel SDO2 cannot be changed.

If a PC or a PLC is used as a master, the identifiers of the **Rx/Tx-SDO1** can be adapted by parameterization on the frequency inverter.

Attention! In free assignment of identifiers, there may not be any double occupancy!

The identifier range 129...191 may not be used as the emergency telegrams can be found there.

The setting of the identifiers of the RxSDO1 is done via the parameter *RxSDO1-Identifier* **921**.

Parameter		Setting		
No.	Description	Min.	Max.	Fact. sett.
921	RxSDO1-Identifier	0	2047	0

The setting of the identifiers of the TxSDO1 is done via parameter number **922**.

Parameter		Setting		
No.	Description	Min.	Max.	Fact. sett.
922	TxSDO1-Identifier	0	2047	0

The setting "0" results in identifier assignment according to the Predefined Connection Set.

The second SDO channel can be deactivated via the *SDO2 Set Active* **923**.

Operation mode	Function
0 - SDO2 deactivated	Communication channel deactivated
1 - SDO2 activated	Communication channel activated for the visualization tool

The identifier assignment for the second SDO channel is always to the specification:

Identifier Rx-SDO2 = 1600 + Node-ID
 Identifier Tx-SDO2 = 1472 + Node-ID

Note: In this way, firm identifiers via which communication takes place are available for the visualization tool.

4.10 Communication channels, SDO1/SDO2

4.10.1 SDO telegrams (SDO1/SDO2)

The service used for the exchange of parameter data is **SDO Segment Protocol Expedited**. The data (type uint, int, long) are exchanged in a telegram.

Access to the parameters in the frequency inverters with a statement of parameter number and data set is displayed via the addressing defined for object access pursuant to the specifications of CANopen via Index/Sub-Index.

Index = parameter number / Sub index = data set.

The data to be transmitted have a length of 2 bytes for uint/int and 4 bytes for long. For standardization and simplification, 4 bytes are always transmitted.

The data are on bytes 4...7 of the SDO telegram.

- uint/int variables are transmitted in bytes 4 and 5 with bytes 6 und 7 = 0.
- long variables are transmitted in bytes 4...7.

Writing parameters:

Client → Server SDO Download (expedited)

0	1	2	3	4	5	6	7
Ctrl. byte	Parameter number		Data set	Data			
0x22	LSB	MSB	0xnn	LSB			MSB
uint/int				LSB	MSB	0x00	0x00
long				LSB	MSB

Server → Client Download Response → Writing process free of errors

0	1	2	3	4	5	6	7
Ctrl. byte	Parameter number		Data set	Data			
0x60	LSB	MSB	0xnn	0			

Server → Client Abort SDO Transfer → Writing process faulty

0	1	2	3	4	5	6	7
Ctrl. byte	Parameter number		Data set	Data			
0x80	LSB	MSB	0xnn	Code	0	0	0

The error code is stated in byte 4 in a faulty reading process (see Table, failure codes).

Attention! Control byte 0x22 for the identification "SDO Download expedited" does not consider the bits "s" (data size indicated) and "n" (number of bytes not containing data). If set, they are ignored. The user is responsible for the number of bytes matching the type of data.

Reading parameters:

Client → Server SDO Upload (expedited)

0	1	2	3	4	5	6	7
Ctrl. byte	Parameter number		Data set	Data			
0x40	LSB	MSB	0xnn	0			

Server → Client Upload Response → Reading process free of errors

0	1	2	3	4	5	6	7
Ctrl. byte	Parameter number		Data set	Data			
0x42	LSB	MSB	0xnn	LSB			MSB
uint/int				LSB	MSB	0x00	0x00
long				LSB	MSB

Server → Client Abort SDO Transfer → Reading process faulty

0	1	2	3	4	5	6	7
Ctrl. byte	Parameter number		Data set	Data			
0x80	LSB	MSB	0xnn	Code	0	0	0

The error code is stated in byte 4 in a faulty reading process (see Table, failure codes).

failure codes	
Code	Description
1	inadmissible parameter figure
2	inadmissible data set
3	parameter not readable
4	parameter not writable
5	reading error EEPROM
6	writing error EEPROM
7	checksum error EEPROM
8	parameter cannot be written during running drive
9	values of the data sets differ
10	parameter of wrong type
11	unknown parameter
12	BCC error in VECTRON bus protocol
15	unknown error
20	system bus node not available only in access via field bus connection
21	string parameter not admissible only in access via VECTRON bus protocol

Errors marked in the table are generated by the field bus side, not in the Abort SDO Transfer of the system bus.

4.10.2 Communication via field bus connection (SDO1)

If a frequency inverter has been defined as the system bus master and equipped with a field bus interface, access to the parameterization of all the nodes in existence on the system bus is possible by means of this field bus interface via the first SDO channel (SDO1). An extension has been created in the protocol frame of the field buses for this purpose.

Attention! The prerequisite for this mechanism is that the identifier setting for the first SDO channel (SDO1) corresponds to the Predefined Connection Set. The parameter addressed must also exist in the system bus master.

4.10.2.1 Profibus-DP

If an object with communication channel (PKW) is used in Profibus-DP, access to all the other nodes on the system bus can be done via it. The structure of the communication channel permits an additional addressing of a system bus node. This is done by the use of an unused byte in the communication channel.

Communication channel PKW

0	1	2	3	4	5	6	7
PKE		Index	-	Data			
AK/SPM	Parameter number	Data set	Node-ID system bus				

Byte 3 is used to transmit the Node ID of the required node on the system bus. If byte 3 = 0, the master inverter of the system bus is addressed. The display is binary (0...63).

4.10.2.2 RS232/RS485 with VECTRON bus protocol

In the VECTRON bus protocol, there is a byte in the telegram header that is always transmitted with 0 as a standard feature.

ENQUIRY

0	1	2	3	4	5	6
Address	0	p	n	n	n	ENQ
	Node-ID system bus	Data set	Parameter number			

SELECT

0	1	2	3	4			
Address	STX	0	p	n	n	n	...
		Node-ID system bus	Data set	Parameter number			

Byte 1 in the enquiry and byte 2 in the select telegram are not defined and are used to transmit the Node ID of the required node on the system bus. If this byte = 0, the master inverter of the system bus is addressed. The display is ASCII corresponding to the conventions for the display of the address in the VECTRON bus protocol.

Note: If there is an NAK fault message, the error is to be read out from the system bus master with node ID = 0 via parameter 11!

Display of node ID system bus in the VECTRON bus protocol:

System bus Node-ID					
System bus address	(ASCII-) character	HEX value	System bus address	(ASCII-) character	HEX value
1	A	41	31	—	5F
2	B	42	32	~	60
3	C	43	33	a	61
4	D	44	34	b	62
5	E	45	35	c	63
6	F	46	36	d	64
7	G	47	37	e	65
8	H	48	38	f	66
9	I	49	39	g	67
10	J	4A	40	h	68
11	K	4B	41	i	69
12	L	4C	42	j	6A
13	M	4D	43	k	6B
14	N	4E	44	l	6C
15	O	4F	45	m	6D
16	P	50	46	n	6E
17	Q	51	47	o	6F
18	R	52	48	p	70
19	S	53	49	q	71
20	T	54	50	r	72
21	U	55	51	s	73
22	V	56	52	t	74
23	W	57	53	u	75
24	X	58	54	v	76
25	Y	59	55	w	77
26	Z	5A	56	x	78
27	[5B	57	y	79
28	\	5C	58	z	7A
29]	5D	59	{	7B
30	^	5E	60		7C
			61	}	7D
			62	~	7E
			63	□	7F

4.11 Process data channels, PDO

4.11.1 Identifier assignment process data channel

The process channel for the exchange of process data under CANopen is the PDO channel. Up to three PDO channels with differing properties can be used in one device.

The PDO channels are defined via identifiers according to the Predefined Connection Set to CANopen:

Identifier 1. Rx-PDO = 512 + Node-ID
 Identifier 1. Tx-PDO = 384 + Node-ID

Identifier 2. Rx-PDO = 768 + Node-ID
 Identifier 2. Tx-PDO = 640 + Node-ID

Identifier 3. Rx-PDO = 1024 + Node-ID
 Identifier 3. Tx-PDO = 896 + Node-ID

This corresponds to the factory settings of the frequency inverters for the Rx/Tx-PDO's. This occupancy is aligned to an external master (PLC/PC) serving all the channels.

If the PDO channels are used for a connection of the frequency inverters amongst one another, the identifiers are to be set accordingly by parameterization.

Attention! In free assignment of identifiers, there may not be any double occupancy!

The identifier range 129...191 may not be used as the emergency telegrams can be found there.

Setting of the identifiers of the Rx/TxPDO's:

Parameter		Setting		
No.	Description	Min.	Max.	Fact. sett.
924	RxPDO1 Identifier	0	2047	0
925	TxPDO1 Identifier	0	2047	0
926	RxPDO2 Identifier	0	2047	0
927	TxPDO2 Identifier	0	2047	0
928	RxPDO3 Identifier	0	2047	0
929	TxPDO3 Identifier	0	2047	0

The setting "0" results in identifier assignment according to the Predefined Connection Set.

4.11.2 Operation modes process data channel

The transmit/receive behavior can be time controlled or controlled via a SYNC telegram. The behavior can be parameterized for each PDO channel.

Tx-PDO's can work time controlled or SYNC controlled. A time controlled TxPDO transmits its data at the interval of time set. A SYNC controlled TxPDO transmits its data after the arrival of a SYNC telegram.

RxPDO's in the time controlled setting forward the received data to the application immediately. If an RxPDO has been defined as SYNC controlled, it forwards its received data to the application after the arrival of a SYNC telegram.

Settings TxPDO1/2/3

Parameter		Setting		
No.	Description	Min.	Max.	Fact. sett.
931	TxPDO1 Time	1 ms	50000 ms	8 ms
933	TxPDO2 Time	1 ms	50000 ms	8 ms
935	TxPDO3 Time	1 ms	50000 ms	8 ms

The setting of the operation mode is done via the following parameters:

TxPDO1 Function 930, TxPDO2 Function 932 und TxPDO3 Function 934

Operation mode	Function
0 - Not Active	No data are sent
1 - Controlled by time	In the cycle of the adjusted time interval the data are sent
2 - Controlled by SYNC	To arrival of a SYNC telegram the data are sent

Settings RxPDO1/2/3

The setting of the operation mode is done via the following parameters:

RxPDO1 Function 936, RxPDO2 Function 937 und RxPDO3 Function 938

Operation mode	Function
0 - Controlled by time	The received data are passed on immediately
1 - Controlled by SYNC	After arrival of a SYNC telegram the received data are passed on

Note: In the "controlled by time" operation mode, there is a polling of the received data with the trigger cycle of $T_a = 1$ ms.

4.11.3 Timeout monitoring process data channel

Each frequency inverter monitors its received data for whether they are updated within a defined time window.

The monitoring is done onto the SYNC telegram and the RxPDO channels.

Monitoring SYNC / RxPDO's

Parameter		Setting		
No.	Description	Min.	Max.	Fact. sett.
939	SYNC Timeout	0 ms	60000 ms	0 ms
941	RxPDO1 Timeout	0 ms	60000 ms	0 ms
942	RxPDO2 Timeout	0 ms	60000 ms	0 ms
945	RxPDO3 Timeout	0 ms	60000 ms	0 ms

Setting 0 means no timeout monitoring.

Attention! There is only monitoring for the SYNC telegram if at least one RxPDO or one TxPDO channel is defined as SYNC controlled.

If a timeout period is exceeded, the frequency inverter breaks down and reports one of the faults:

F2200 System bus Timeout SYNC

**F2201 System bus Timeout
RxPDO1**

**F2202 System bus Timeout
RxPDO2**

**F2203 System bus Timeout
RxPDO3**

4.11.4 Communication relationships of the process data channel

Regardless of the process data to be transmitted, the communication relationships of the process data channels must be defined. The connection of PDO channels is done via the assignment of the identifiers. The identifiers of Rx-/Tx-PDO must match in each case.

There are two principal possibilities:

- **one** Rx-PDO to **one** Tx-PDO (one to one)
- connect **several** Rx-PDO's to **one** Tx-PDO (one to many)

This process is documented in a tabular form via a **communication relationship list**.

Example:

Frequency inverter 1		Frequency inverter 2		Frequency inverter 3	
PDO	Identifier	PDO	Identifier	PDO	Identifier
TxPDO1	385	TxPDO1		TxPDO1	
RxPDO1		RxPDO1	385	RxPDO1	385
TxPDO2	641	TxPDO2		TxPDO2	642
RxPDO2		RxPDO2	641	RxPDO2	
TxPDO3		TxPDO3		TxPDO3	
RxPDO3		RxPDO3	642	RxPDO3	

Attention! All the TxPDO's used must have differing identifiers!
The Identifier must be clear in the system bus network.

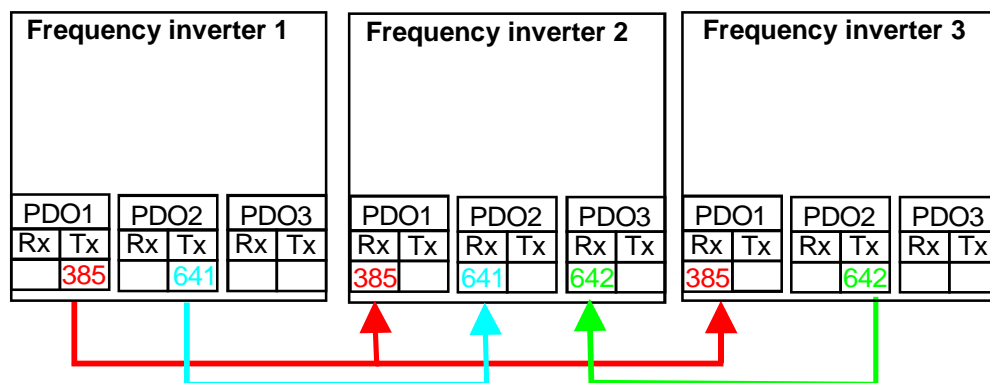

4.11.5 Virtual links

According to CANopen, a PDO telegram contains 0..8 data bytes. A mapping for any kind of objects can be done in these data bytes.

For the system bus, the PDO telegrams are firmly defined with 8 data bytes. The mapping is not done via mapping parameters as with CANopen, but via the method of sources and links.

Each function provides its output data via a source. These sources are defined via source numbers. The input data of functions are defined via parameters. The link of a data input to a data output is done via the assignment of parameters to source numbers.

Example 1:

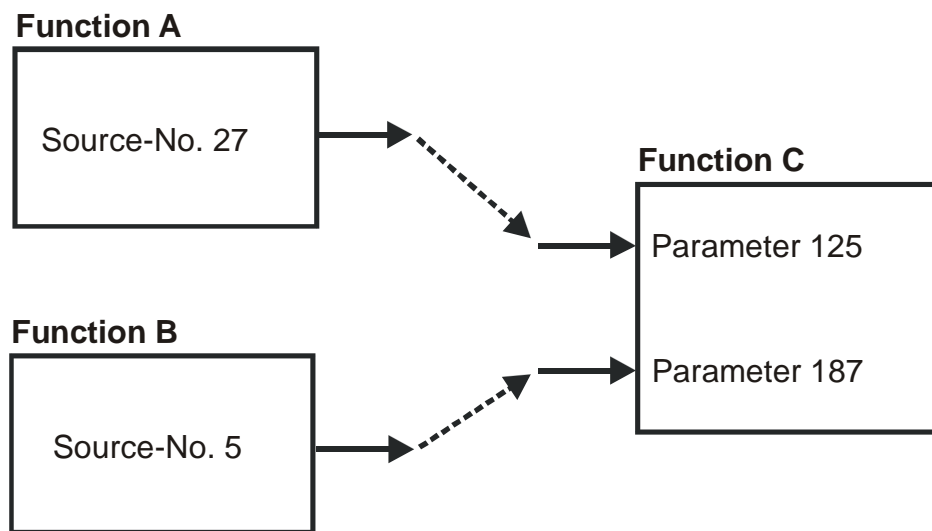

In example 1, the two inputs of function C are connected with the outputs of functions A and B. Thus, the parameterization for this connection is:

Function C

Parameter 125 = Source-No. 27
 Parameter 187 = Source-No. 5

Example of a virtual link in VPlus:

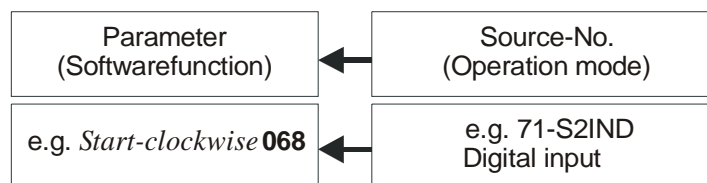

The assignment of the operation modes to the software functions available can be adapted to the application in question.

For the system bus, the input data of the TxPDO's are also displayed as input parameters and the output data of the RxPDO's as sources.

Example 2:

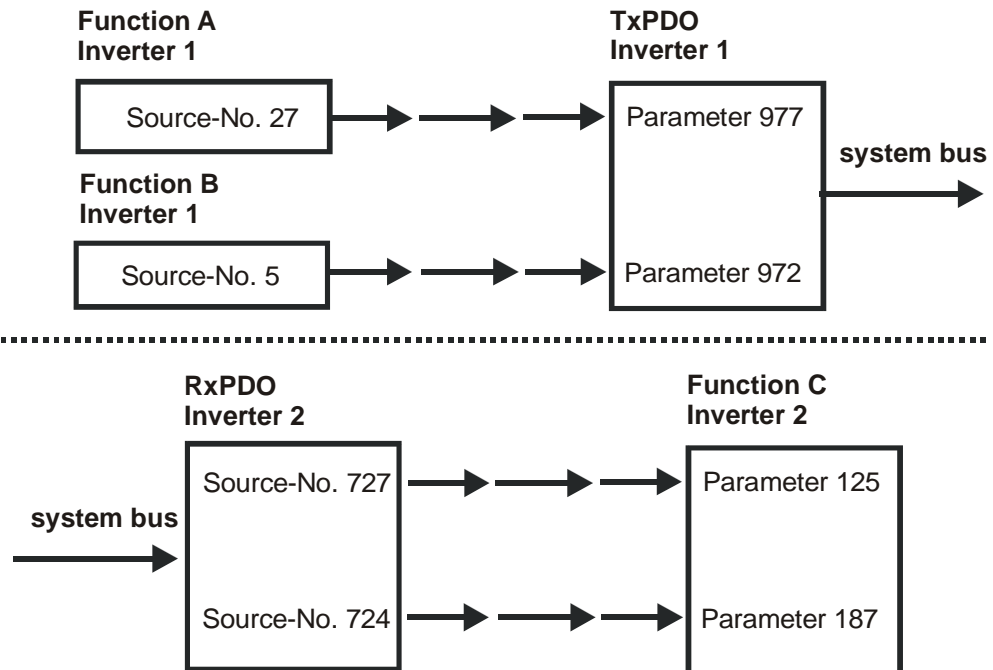

Example 2 displays the same situation as Example 1. But now, the functions A and B are in frequency inverter 1 and function C in frequency inverter 2. The connection is done via a TxPDO in frequency inverter 1 and a RxPDO in frequency inverter 2. Thus, the parameterization for this connection is:

Frequency inverter 1

Parameter 977 = Source-No. 27
 Parameter 972 = Source-No. 5

Frequency inverter 2

Parameter 125 = Source-No. 727
 Parameter 187 = Source-No. 724

As the links with the system used exceed the device limits, they are termed "virtual links".

The virtual links with the possible sources are related to the Rx/TxPDO channels. For this purpose, the eight bytes of the Rx-/TxPDO's are defined structured as inputs and sources. This exists for each of the three PDO channels.

Each transmit PDO and receive PDO can be occupied as follows:

4 Boolean variables

or

4 uint/int variables 4 uint/int variables

or

2 long variables

or

a mixture paying attention to the eight bytes available

Assignment data type / number of bytes:

Assignment	
Data type	Length
Boolean	2 Bytes
uint/int	2 Bytes
long	4 Bytes

4.11.5.1 Input parameters of the TxPDO's for data to be transmitted

The listed parameters can be used to stipulate the data that are to be transported there for each position in the TxPDO telegrams. The setting is done in such a way that a source number is entered for the required data in the parameters.

TxPDO1 Byte	P. No. Boolean input	TxPDO1 Byte	P. No. uint/int input	TxPDO1 Byte	P. No. long input
0	946	0	950	0	954 Long1
1	Boolean1	1	Word1	1	
2	947	2	951	2	
3	Boolean2	3	Word2	3	955 Long2
4	948	4	952	4	
5	Boolean3	5	Word3	5	
6	949	6	953	6	
7	Boolean4	7	Word4	7	

TxPDO2 Byte	P. No. Boolean input	TxPDO2 Byte	P. No. uint/int input	TxPDO2 Byte	P. No. long input
0	956	0	960	0	964 Long1
1	Boolean1	1	Word1	1	
2	957	2	961	2	
3	Boolean2	3	Word2	3	965 Long2
4	958	4	962	4	
5	Boolean3	5	Word3	5	
6	959	6	963	6	
7	Boolean4	7	Word4	7	

TxPDO3 Byte	P. No. Boolean input	TxPDO3 Byte	P. No. uint/int input	TxPDO3 Byte	P. No. long input
0	966	0	972	0	976 Long1
1	Boolean1	1	Word1	1	
2	967	2	973	2	
3	Boolean2	3	Word2	3	977 Long2
4	968	4	974	4	
5	Boolean3	5	Word3	5	
6	969	6	975	6	
7	Boolean4	7	Word4	7	

Note: Depending on the selected data information the percentages values are displayed via the uint/int inputs!

With this method, there are up to three possibilities for a meaning of the contents of the individual bytes. Each byte may only be used for one possibility.

To ensure this, the processing of the input links is derived from the setting. If an input link has been set to the fixed value of zero, it is **not** processed.

The settings for the fixed value zero are:

Source = 7 (FALSE) for boolean variables
 Source = 9 (0) for uint/int, long variables

This is simultaneously the factory setting.

Examples Boolean source

Boolean source	
Source	Data
6	TRUE
7	FALSE
70	Contact input 1
71	Contact input 2
72	Contact input 3
161	Running message
163	Nominal figure reached
164	Set frequency reached (P. 510)

Examples uint/int source

uint/int source	
Source	Data
9	0
63	Reference percentage 1
64	Reference percentage 2
52	Percentage MF11
133	Output percentage ramp
137	Output reference percentage channel
138	Output actual percentage channel
740	Control word
741	State word

Examples long source

long source	
Source	Data
9	0
0	Output frequency ramp
1	Fixed frequency 1
5	Reference line value
62	Output frequency reference value channel
50	Reference frequency MF11

4.11.5.2 Source numbers of the RxPDO's for received data

Equivalent to the input links of the TxPDO's, the received data of the RxPDO's are displayed via sources or source numbers. The sources existing in this way can be used in the frequency inverter via the local input links for the data targets.

RxPDO1 Byte	Source No. Boolean value	RxPDO1 Byte	Source No. uint/int value	RxPDO1 Byte	Source No. long- Value
0	700	0	704	0	708 Long1
1	Boolean1	1	Word1	1	
2	701	2	705	2	
3	Boolean2	3	Word2	3	709 Long2
4	702	4	706	4	
5	Boolean3	5	Word3	5	
6	703	6	707	6	
7	Boolean4	7	Word4	7	

RxPDO2 Byte	Source No. Boolean value	RxPDO2 Byte	Source No. uint/int value	RxPDO2 Byte	Source No. long value
0	710	0	714	0	718 Long1
1	Boolean1	1	Word1	1	
2	711	2	715	2	
3	Boolean2	3	Word2	3	719 Long2
4	712	4	716	4	
5	Boolean3	5	Word3	5	
6	713	6	717	6	
7	Boolean4	7	Word4	7	

RxPDO3 Byte	Source No. Boolean value	RxPDO3 Byte	Source No. uint/int value	RxPDO3 Byte	Source No. long value
0	720	0	724	0	728 Long1
1	Boolean1	1	Word1	1	
2	721	2	725	2	
3	Boolean2	3	Word2	3	729 Long2
4	722	4	726	4	
5	Boolean3	5	Word3	5	
6	723	6	727	6	
7	Boolean4	7	Word4	7	

With this method, there are up to three possibilities for a meaning of the contents of the individual bytes. Each byte may only be used for one possibility.

Note: Depending on the selected data information the percentages values are displayed via the uint/int inputs!

4.11.5.3 Examples of virtual links

Example 1:

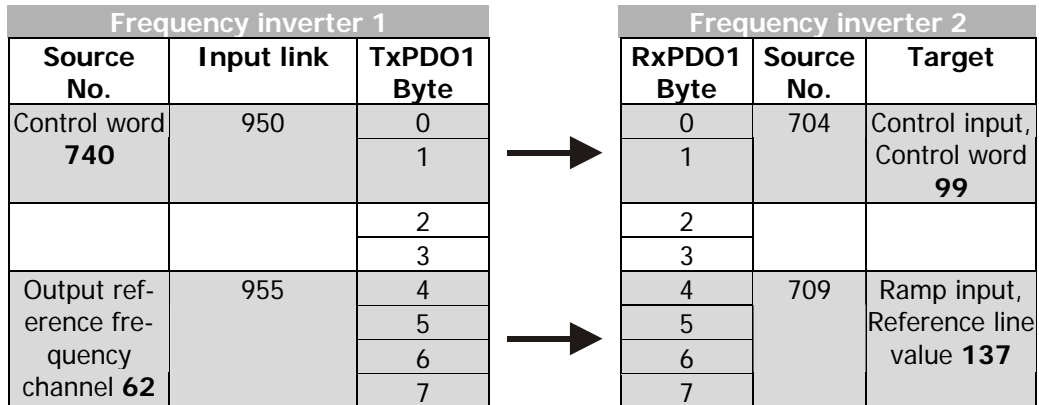

Parameter 950 = Source-No. 740
Parameter 955 = Source-No. 62

Parameter 99 = Source-No. 704
Parameter 137 = Source-No. 709

The control word of frequency inverter 1 is linked with the control word of frequency inverter 2. In this way, both frequency inverters can be operated synchronously via the remote control. The output of the reference value channel of frequency inverter 1 is laid onto the output of the ramp of frequency inverter 2. In this way, both frequency inverters have a joint source of reference values and are given reference values in the internal notation.

As an extension, a number of frequency inverters can also exist on the receive side (Rx), these then being supplied with data parallel and simultaneously.

The input link not used in the TxPDO1 of frequency inverter 1 is on ZERO and is thus not served.

Example 2:

Example of a virtual link with transmission via the system bus:

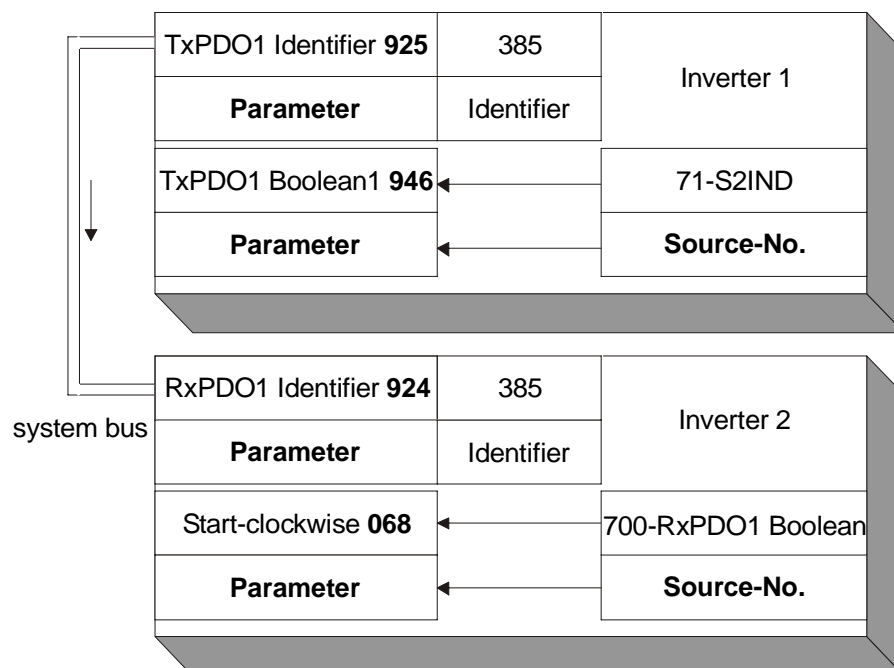

4.12 Control parameters

For the monitoring of the system bus and the display of the internal states, two control parameters are provided. There is a report of the system bus state and a report of the CAN state via two actual value parameters.

The parameter *Node-State* **978** gives information about the Pre-Operational, Operational, Stopped state. A PDO transfer is only possible in the Operational state. The state is controlled by the system bus master (PLC / PC / frequency inverter) via NMT telegrams.

The parameter *CAN-State* **979** gives information about the state of the physical layer. If there are transmission errors, the state changes from OKAY to WARNING until the cancellation of the communication with BUS-OFF. After BUS-OFF, the CAN controller is automatically re-initialized and the system bus started again.

Note: If the BUS-OFF state occurs, the frequency inverter breaks down with "**F2210 BUS-OFF**".

After Bus-OFF, the system bus in the frequency inverter is completely reinitialized. There is a new boot-up message from the node and an emergency telegram with the Bus-OFF message is transmitted. The change of state of the node to Operational is done by the Start-Remote-Node telegram cyclically sent by the system bus master.

Actual values of the system bus		
No.	Description	Function
978	Node-State	1 - Pre-Operational 2 - Operational 3 - Stopped
979	CAN-State	1 - OKAY 2 - WARNING 3 - BUS-OFF

4.13 Handling of the parameters of the system bus

As soon as the system bus expansion module EM-SYS exists in an frequency inverter, the actual value parameters for system state and bus state are activated and can be observed in the actual value menu **VAL** of the control unit KP500 or with the VPlus PC program in the menu **Actual values \ System bus**.

Note: The actual value parameters are on control level 3 and are thus available for the user at any time.

All the setting parameters for the configuration of the system bus are not directly accessible for the user. For defined customer applications, pre-defined XPI files can be generated by VECTRON for the VPlus PC program, with which the necessary parameters are visible for the user. The application-relevant variables are then available in these XPI files.

Note: XPI files can be read in addition to the loaded parameter information of the frequency inverter into the VPlus PC program.
In the menu of the software under the point Edit you find the command "Read in XPI file".

The method of working via an XPI file has its reasoning in the fact that deep interventions in the system are possible via the system bus and can lead to serious problems in the application with an untrained user. Via the XPI files, a user is given a selection list pre-defined by VECTRON.

Attention! The configuration of the necessary parameters for the system bus are accessible by a XPI file with the help of the VPlus PC program.
The control unit KP500 does not support this functionality.
If the expansion module system bus EM-SYS is installed additionally to a communication module for the field bus connection (CM-232, CM-485 or CM-PDP) in the frequency inverter, the parameterization can be made with the interface adapter KP232.

Experienced users have complete access to all the existing sources and possible input links with the XPI file of the active functions. The selection depends on the selected configuration and control procedure.

The display of the parameters when using the XPI file is according to the following structure:

system bus	
Basic Settings	900Node-ID 903Baud-Rate
Master Functions	904Boot-Up Delay 919SYNC-Time
SYNC-Identifier	918SYNC-Identifier
SDO1-Identifier	921RxSDO1-Identifier 922TxSDO1-Identifier
SDO2 Set Active	923SDO2 Set Active
PDO-Identifier	924RxPDO1-Identifier 925TxPDO1-Identifier 926RxPDO2-Identifier 927TxPDO2-Identifier 928RxPDO3-Identifier 929TxPDO3-Identifier

TxPDO-Function	930TxPDO1 Function 931TxPDO1 Time 932TxPDO2 Function 933TxPDO2 Time 934TxPDO3 Function 935TxPDO3 Time
RxPDO-Function	936RxPDO1 Function 937RxPDO2 Function 938RxPDO3 Function
Timeout	939SYNC Timeout 941RxPDO1 Timeout 942RxPDO2 Timeout 945RxPDO3 Timeout
TxPDO1 Objects	946TxPDO1 Boolean1 947TxPDO1 Boolean2 948TxPDO1 Boolean3 949TxPDO1 Boolean4 950TxPDO1 Word1 951TxPDO1 Word2 952TxPDO1 Word3 953TxPDO1 Word4 954TxPDO1 Long1 955TxPDO1 Long2
TxPDO2 Objects	956TxPDO2 Boolean1 957TxPDO2 Boolean2 958TxPDO2 Boolean3 959TxPDO2 Boolean4 960TxPDO2 Word1 961TxPDO2 Word2 962TxPDO2 Word3 963TxPDO2 Word4 964TxPDO2 Long1 965TxPDO2 Long2
TxPDO3 Objects	966TxPDO3 Boolean1 967TxPDO3 Boolean2 968TxPDO3 Boolean3 969TxPDO3 Boolean4 972TxPDO3 Word1 973TxPDO3 Word2 974TxPDO3 Word3 975TxPDO3 Word4 976TxPDO3 Long1 977TxPDO3 Long2
Actual values	
system bus	978Node-State 979CAN-State

4.14 Utilities

For the planning of the system bus according to the drive tasks in question, there are utilities in the form of tables.

The planning of the system bus is done in three steps:

1. Definition of the communication relationships
2. Production of the virtual links
3. Capacity check

The priority assignment of the identifiers is relevant for the definition of the communication relationships. Data that are to be transmitted with a higher priority must be given low identifiers. This results in the message with the higher priority being transmitted first with a simultaneous access of two nodes to the bus.

Note: The recommended identifier range for the communication relationships via the PDO channels is 385 ... 1407.

The identifiers below 385 are used for the NMT telegrams (boot-up sequence, SYNC telegram) and emergency message.

The identifiers above 1407 are used for the SDO channel for parameterization.

4.14.2 Production of the virtual links

The virtual links are planned and documented with the help of the table. The table is available as a Microsoft Word document "vvk.doc" on the BONFIGLIOLI VECTRON product CD or upon request.

Inverter: _____	Node-ID: _____ RxPDO-No.: _____	Source-No.	
Identifier: _____ (Tx/RxPDO)	Inverter: _____	Node-ID: _____ TxPDO-No.: _____	Source-No.
			
Inverter: _____	Node-ID: _____ TxPDO-No.: _____	Input Link/Parameter-No.	long
		Boolean	uint/int

4.14.3 Capacity planning of the system bus

Each PDO telegram possesses a constant useful data content of 8 Bytes. According to worst case, this results in a maximum telegram length of 140 bits. The maximum telegram run time of the PDO's is thus stipulated via the set baud rate.

Capacity planning	
Baud rate / kBaud	Telegram run time / μ s
1000	140
500	280
250	560
125	1120
100	1400
50	2800

As a function of the set baud rate and the transmission interval of the TxPDO's selected, the following bus loads results:

Capacity of the system bus										
Baud rate / kBaud	Bus load as a function of the transmission for one TxPDO in %									
	1ms	2ms	3ms	4ms	5ms	6ms	7ms	8ms	9ms	10ms
1.000	14	7	4.7	3.5	2.8	2.3	2	1.8	1.6	1.4
500	28	14	9.3	7	5.6	4.7	4	3.5	3.1	2.8
250	56	28	18.7	14	11.2	9.3	8	7	6.2	5.6
125	112	56	37.3	28	22.4	18.7	16	14	12.4	11.2
100	140	70	46.7	35	28	23.3	20	17.5	15.6	14
50	280	140	93.3	70	56	46.7	40	35	31.1	28

Attention! A bus load >100% means that a telegram cannot be dispatched completely between two transmission times.

Such a setting is not admissible!

This observation must be done for each TxPDO. The sum of all the TxPDO's decides on the entire bus load. The bus load must be designed in such a way that any telegram repetitions for transmission errors are possible without exceeding the bus capacity.

Note: To facilitate capacity planning, a Microsoft Excel file with the name "Load_Systembus.xls" is available.

The capacity planning are planned and documented with the help of the table. The work sheet is available as a Microsoft Excel document "Load_Systembus.xls" on the BONFIGLIOLI VECTRON product CD or by request.

Load system bus			
Baud rate [kBaud]: 50, 100, 125, 250, 500, 1000			1000
Frequency inverter	TxPDO Number	Ta [ms]	Load [%]
1	1	0	0
	2	0	0
	3	0	0
2	1	0	0
	2	0	0
	3	0	0
3	1	0	0
	2	0	0
	3	0	0
4	1	0	0
	2	0	0
	3	0	0
5	1	0	0
	2	0	0
	3	0	0
6	1	0	0
	2	0	0
	3	0	0
7	1	0	0
	2	0	0
	3	0	0
8	1	1	14
	2	1	14
	3	1	14
9	1	1	14
	2	1	14
	3	0	0
10	1	0	0
	2	0	0
	3	0	0
Total load [%]			70

In the table, the set baud rate is entered from the parameter *Baud-Rate 903* in kBaud. For each frequency inverter, the set time for the transmission interval (e. g. *TxPDO1 Time 931*) in ms is entered for the TxPDO being used at the time. In the column **Load** the bus load caused by the individual TxPDO appears, under **Total Load** the entire bus load.

For the bus load (Total load) the following limits have been defined:

- ≤ 80 % → OKAY
- 80 ... 90 % → CRITICAL
- > 90 % → NOT POSSIBLE

5 Parameter list

The parameter list is structured according to the menu branches of the control unit. For better clarity, the parameters are marked with pictograms.

-  The parameter is available in the four data sets.
- The parameter value is set by the SETUP routine.
- This parameter cannot be written in the operation of the frequency inverter.

5.1 Actual value menu (VAL)

Actual values of the system bus				
No.	Description	Unit	Display range	Chapter
978	Node-State	-	1 ... 3	4.12
979	CAN-State	-	1 ... 3	4.12

5.2 Parameter menu (PARA)

System bus				
No.	Description	Unit	Setting range	Chapter
900	Node-ID	-	-1 ... 63	4.5
903	Baud-Rate	-	Selection	4.4
904	Boot-Up Delay	ms	3500 ... 50000	4.8.4
918	SYNC-Identifier	-	0 ... 2047	4.8.2
919	SYNC-Time	ms	0 ... 50000	4.9.2
921	RxSDO1-Identifier	-	0 ... 2047	4.9.4
922	TxSDO1-Identifier	-	0 ... 2047	4.9.4
923	SDO2 Set Active	-	Selection	4.9.4
924	RxPDO1-Identifier	-	0 ... 2047	4.11.1
925	TxPDO1-Identifier	-	0 ... 2047	4.11.1
926	RxPDO2-Identifier	-	0 ... 2047	4.11.1
927	TxPDO2-Identifier	-	0 ... 2047	4.11.1
928	RxPDO3-Identifier	-	0 ... 2047	4.11.1
929	TxPDO3-Identifier	-	0 ... 2047	4.11.1
930	TxPDO1 Function	-	Selection	4.11.2
931	TxPDO1 Time	ms	0 ... 50000	4.11.2
932	TxPDO2 Function	-	Selection	4.11.2
933	TxPDO2 Time	ms	0 ... 50000	4.11.2
934	TxPDO3 Function	-	Selection	4.11.2
935	TxPDO3 Time	ms	0 ... 50000	4.11.2
936	RxPDO1 Function	-	Selection	4.11.2
937	RxPDO2 Function	-	Selection	4.11.2
938	RxPDO3 Function	-	Selection	4.11.2
939	SYNC Timeout	ms	0 ... 60000	4.11.3
941	RxPDO1 Timeout	ms	0 ... 60000	4.11.3
942	RxPDO2 Timeout	ms	0 ... 60000	4.11.3
945	RxPDO3 Timeout	ms	0 ... 60000	4.11.3
946	TxPDO1 Boolean1	-	Selection	4.11.5.1
947	TxPDO1 Boolean2	-	Selection	4.11.5.1
948	TxPDO1 Boolean3	-	Selection	4.11.5.1
949	TxPDO1 Boolean4	-	Selection	4.11.5.1

Table continued on next page.

System bus				
No.	Description	Unit	Setting range	Chapter
950	TxPDO1 Word1	-	Selection	4.11.5.1
951	TxPDO1 Word2	-	Selection	4.11.5.1
952	TxPDO1 Word3	-	Selection	4.11.5.1
953	TxPDO1 Word4	-	Selection	4.11.5.1
954	TxPDO1 Long1	-	Selection	4.11.5.1
955	TxPDO1 Long2	-	Selection	4.11.5.1
956	TxPDO2 Boolean1	-	Selection	4.11.5.1
957	TxPDO2 Boolean2	-	Selection	4.11.5.1
958	TxPDO2 Boolean3	-	Selection	4.11.5.1
959	TxPDO2 Boolean4	-	Selection	4.11.5.1
960	TxPDO2 Word1	-	Selection	4.11.5.1
961	TxPDO2 Word2	-	Selection	4.11.5.1
962	TxPDO2 Word3	-	Selection	4.11.5.1
963	TxPDO2 Word4	-	Selection	4.11.5.1
964	TxPDO2 Long1	-	Selection	4.11.5.1
965	TxPDO2 Long2	-	Selection	4.11.5.1
966	TxPDO3 Boolean1	-	Selection	4.11.5.1
967	TxPDO3 Boolean2	-	Selection	4.11.5.1
968	TxPDO3 Boolean3	-	Selection	4.11.5.1
969	TxPDO3 Boolean4	-	Selection	4.11.5.1
972	TxPDO3 Word1	-	Selection	4.11.5.1
973	TxPDO3 Word2	-	Selection	4.11.5.1
974	TxPDO3 Word3	-	Selection	4.11.5.1
975	TxPDO3 Word4	-	Selection	4.11.5.1
976	TxPDO3 Long1	-	Selection	4.11.5.1
977	TxPDO3 Long2	-	Selection	4.11.5.1
989	Emergency Reaction	-	Selection	4.8.3

6 Annex

6.1 Error messages

The various control functions and methods and the hardware of the frequency inverter contain functions which continuously monitor the application. As a supplement to the messages documented in these operating instructions, the following failure keys are activated by the EM-SYS expansion module.

System bus error messages		
F21	nn	Fault report to system bus master in fault in system bus slave nn = Node ID of slave (hex)
F22	00	Communication fault, system bus, timeout SYNC telegram
	01	Communication fault, system bus, timeout RxPDO1
	02	Communication fault, system bus, timeout RxPDO2
	03	Communication fault, system bus, timeout RxPDO3
	10	Communication fault, system bus, bus OFF

Alongside the fault messages stated, there are further fault messages, however they are only used for internal purposes and are not listed here. If you receive fault messages which are not listed here, please contact us by phone.



Bonfiglioli Worldwide & BEST Partners

AUSTRALIA

BONFIGLIOLI TRANSMISSION (Aust) Pty Ltd.
48-50 Adderley St. (East) Auburn (Sydney) N.S.W. 2144
Tel. (+61) 2 8748 4400 - Fax (+61) 2 9748 8740
P.O. Box 6705 Silverwater NSW 1811
www.bonfiglioli.com.au - bta1@bonfiglioli.com.au

AUSTRIA **BEST**

MOLL MOTOR GmbH
Industriestrasse 8 - 2000 Stockerau
Tel. (+43) 2266 63421+DW - Fax (+43) 6342 180
Tlx 61 32 22 348 Molla
www.mollmotor.at - office@mollmotor.at

BELGIUM **BEST**

N.V. ESCO TRANSMISSION S.A.
Culliganlaan 3 - 1831 Machelem Diegem
Tel. 0032 2 7204880 - Fax 0032 2 7212827
Tlx 21930 Escopo B
www.escotrans.be - info@escotrans.be

BRASIL **BEST**

ATI BRASIL
Rua Omlio Monteiro Soares, 260 - Vila Fanny - 81030-000
Tel. (+41) 334 2091 - Fax (+41) 332 8669
www.atibrasil.com.br - vendas@atibrasil.com.br

CANADA

BONFIGLIOLI CANADA INC.
2-7941 Jane Street - Concord, ONTARIO L4K 4L6
Tel. (+1) 905 7384466 - Fax (+1) 905 7389833
www.bonfigliolicanada.com - sales@bonfigliolicanada.com

CHINA

BONFIGLIOLI DRIVES (SHANGHAI) CO. LTD.
No. 8 Building, Area C1 - 318
SuHong Road, Qingpu, Shanghai 201700
Tel. +86 21 69225500 - Fax +86 21 69225511
www.bonfiglioli.cn - linkn@bonfiglioli.com

FRANCE

BONFIGLIOLI TRANSMISSIONS S.A.
Rue Eugène Pottier BP 19
Zone Industrielle de Moimont II - 95670 Marly la Ville
Tel. (+33) 1 34474510 - Fax (+33) 1 34688800
www.bonfiglioli.fr - btf@bonfiglioli.fr

GERMANY

BONFIGLIOLI DEUTSCHLAND GmbH
Hamburger Straße 18 - 41540 Dormagen
Tel. (+49) 2133 50260 - Fax (+49) 2133 502610
www.bonfiglioli.de - info@bonfiglioli.de

GREAT BRITAIN

BONFIGLIOLI UK Ltd
Unit 3 Colemeadow Road - North Moors Moat
Redditch, Worcestershire B98 9PB
Tel. (+44) 1527 65022 - Fax (+44) 1527 61995
www.bonfiglioli.co.uk - manwaha@bonfiglioli.com

BONFIGLIOLI (UK) LIMITED
5 Grosvenor Grange - Woolston - Warrington, Cheshire WA1 4SF
Tel. (+44) 1925 852667 - Fax (+44) 1925 852668
www.bonfiglioliuk.co.uk - sales@bonfiglioliuk.co.uk

GREECE

BONFIGLIOLI HELLAS
O.T. 48A T.O. 230 - C.P. 570 22 Industrial Area - Thessaloniki
Tel. (+30) 2310 796456 - Fax (+30) 2310 795903
www.bonfiglioli.gr - info@bonfiglioli.gr

HOLLAND **BEST**

ELSTO AANDRIJFTECHNIEK
Loosterweg, 7 - 2215 TL Voorhout
Tel. (+31) 252 219 123 - Fax (+31) 252 231 660
www.elsto.nl - imfo@elsto.nl

HUNGARY **BEST**

AGISYS AGITATORS & TRANSMISSIONS Ltd
2045 Törökbalint, Tö u.2. Hungary
Tel. +36 23 50 11 50 - Fax +36 23 50 11 59
www.agisys.hu - info@agisys.com

INDIA

BONFIGLIOLI TRANSMISSIONS PVT Ltd.
PLOT AC7-AC11 Sidco Industrial Estate
Thirumudivakkam - Chennai 600 044
Tel. +91(0)44 24781035 / 24781036 / 24781037
Fax +91(0)44 24780091 / 24781904
www.bonfiglioli.co.in - bonfig@vsnl.com

NEW ZEALAND **BEST**

SAECO BEARINGS TRANSMISSION
36 Hastie Avenue, Mangere
Po Box 22256, Otahuhu - Auckland
Tel. +64 9 634 7540 - Fax +64 9 634 7552
mark@saeco.co.nz

POLAND **BEST**

POLPACK Sp. z o.o. - Ul. Chrobrego 135/137 - 87100 Torun
Tel. 0048.56.6559235 - 6559236 - Fax 0048.56.6559238
www.polpack.com.pl - polpack@polpack.com.pl

RUSSIA **BEST**

FAM
57, Maly prospekt, V.O. - 199048, St. Petersburg
Tel. +7 812 3319333 - Fax +7 812 3271454
www.fam-drive.ru - info@fam-drive.ru

SPAIN

TECNOTRANS SABRE S.A.
Pol. Ind. Zona Franca sector C, calle F, n°6 08040 Barcelona
Tel. (+34) 93 4478400 - Fax (+34) 93 3360402
www.tecnotrans.com - tecnotrans@tecnotrans.com

SOUTH AFRICA

BONFIGLIOLI POWER TRANSMISSION Pty Ltd.
55 Galaxy Avenue, Linbro Business Park - Sandton
Tel. (+27) 11 608 2030 OR - Fax (+27) 11 608 2631
www.bonfiglioli.co.za - bonfigsales@bonfiglioli.co.za

SWEDEN

BONFIGLIOLI SKANDINAVIEN AB
Kontorsgatan - 234 34 Lomma
Tel. (+46) 40 412545 - Fax (+46) 40 414508
www.bonfiglioli.se - info@bonfiglioli.se

THAILAND **BEST**

K.P.T MACHINERY (1993) CO.LTD.
259/83 Soi Phiboonves, Sukhumvit 71 Rd. Phrakonong-nur,
Wattana, Bangkok 10110
Tel. 0066.2.3913030/7111998
Fax 0066.2.7112852/3811308/3814905
www.kpt-group.com - sales@kpt-group.com

USA

BONFIGLIOLI USA INC
1000 Worldwide Boulevard - Hebron, KY 41048
Tel.: (+1) 859 334 3333 - Fax (+1) 859 334 8888
www.bonfiglioliusa.com
industrialsales@bonfiglioliusa.com
mobilesales@bonfiglioliusa.com

VENEZUELA **BEST**

MAQUINARIA Y ACCESORIOS IND.-C.A.
Calle 3B - Edif. Comindu - Planta Baja - Local B
La Urbina - Caracas 1070
Tel. 0058.212.2413570 / 2425268 / 2418263
Fax 0058.212.2424552
Tlx 24780 Maica V
www.maica-ve.com - maica@telcel.net.ve

HEADQUARTERS

BONFIGLIOLI RIDUTTORI S.p.A.
Via Giovanni XXIII, 7/A
40012 Lippo di Calderara di Reno

Tel. (+39) 051 6473111
Fax (+39) 051 6473126
www.bonfiglioli.com
bonfiglioli@bonfiglioli.com

SPARE PARTS BONFIGLIOLI

B.R.T.
Via Castagnini, 2-4
Z.I. Bargellino - 40012
Calderara di Reno - Bologna (ITALY)
Tel. (+39) 051 727844
Fax (+39) 051 727066
www.brtonfiglioliricambi.it
brt@bonfiglioli.com



**ACTIVE and
ACTIVE Cube**

www.bonfiglioli.com

 **BONFIGLIOLI**